

LiFePO4 Battery (Bluetooth)

Specification

Model: TB-BL1220F-S115D



SHENZHEN TOPBAND NEW ENERGY CO.,LTD

Address: Topband Industrial Park,Liyuan Industrial Zone,Shiyan,Bao'an,Shenzhen, China,518108.

Web: www.topband.com.cn

Registered	Chen Xiaomin	Customer	
Checked	Thomas	Customer Model	
Approved	Lili	Customer Reback:	
Issued Date	2016-2-16		
Issued Version	V01		

1. General Information

This specification defines the performance of rechargeable LiFePO4 battery pack TB-BL1220F-S115D manufactured by SHENZHEN TOPBAND NEW ENERGY CO.,LTD, describes the type, performance, technical characteristics, warning and caution of the battery pack. The battery pack support Bluetooth communication function. Through installation a Android application (TBEnergy.apk) on mobile terminal, the user can read the battery pack system information.

2. Specification

NO	Items	Description	
Normal specification			
1	Nominal Voltage	12.8V	
2	Normal Capacity	20Ah	
3	Internal Resistance	≤50mΩ	
Standard Charge			
4	Battery operation temperature range @charging	0~45℃	
5	Normal charge voltage	14.6±0.1V	
6	Recommended float charge voltage(for Standby use)	13.9±0.1V	
7	Allowed MAX charge current	20A@Battery initial Temp 25±5℃	
8	Recommended charge current	≤10A	
Standard discharge			
9	Battery operation temperature range @discharging	-20~60℃	
10	Output Voltage Range	8.0~14.6V	
11	Allowed discharge current	30A withstand 30min @Battery initial Temp 25±5℃	
12	Pulse discharge current	55A withstand 3s	
13	Discharge Cut-off voltage	8.0V	
Mechanical Characteristics			
14	Dimension	Length 181±2mm	
		Width 76±2mm	
		Height 165±2mm	
15	Weight	Approx. 3.0Kg	
Storage			
16	Storage Temperature & Humidity Range	Short: within one month	-20~35℃, 45~75%RH
		Long term: above one month	-10~30℃, 45~75%RH
17	Self-discharge rate	Residual capacity	≤3% per month; ≤15% per year
		Reversible capacity	≤1.5%per month; ≤8% per year

3. Electrical Characteristics & Test Condition

Testing Conditions: Ambient Temperature: $25\pm 5^{\circ}\text{C}$; Humidity: 45%~75%.

NO	Items	Criterion	Condition	
1	Internal Impedance	$\leq 50\text{m}\Omega$	Test the internal resistance of 50% SOC battery pack with 1 kHz AC internal resistance test instrument.	
2	Capacity	$\geq 20\text{Ah}$	Rest for 1 hour after fully charged, then discharge with 0.33C current until the battery reaches the discharge cutoff voltage. Repeat above process for three times, if the discharge time is not less than 180 minutes, you can stop and define the Discharging current*time value (Ah) as battery capacity.	
3	Short circuit protection	Automatically cutoff discharging when short circuit, and release after remove the lead.	Connect the positive and negative of this battery pack through a lead with the resistance less than $5\text{m}\Omega$.	
4	MAX charge Current	20A	Charging with this current for more than 0.5h and the added temperature of battery pack less than 20°C .	
5	MAX discharge Current	30A	Discharging with this current for more than 0.5h and the added temperature of battery pack less than 35°C .	
6	Cycle life (DOD%100)	$\geq 2000\text{cycle}$	Discharge with the current of 0.5C until it can't discharge, and then rest it for 1h. Charge the battery following CC(0.33C)/CV(14.6V) mode to full capacity, and then rest it for 1h. Repeat above process until full charged capacity is no more than 80% of normal value. Accumulated times is defined as cycle life.	
7	Discharge Temperature Characteristics	-20°C	$\geq 70\%$	At $25\pm 5^{\circ}\text{C}$ discharge the battery with the current of 0.33C to the cut-off voltage. Store the battery at various temperatures for 2h and discharge the battery with 0.33C to the cut-off voltage. Record the ratio between discharging & charging capacity.
		0°C	$\geq 80\%$	
		25°C	100%	
		55°C	$\geq 95\%$	
8	Charge Retention ability	remain capacity $\geq 90\%$	Charge the battery to full capacity and store it for 28days, and then discharge it with 0.33C to the cut-off voltage.	

4. Circuit Protection

The batteries are supplied with a LiFePO4 Battery Management System (BMS) that can monitor and optimized each single prismatic cell during charge & discharge, to protect the battery pack overcharge, over discharge, short circuit. Overall, the BMS helps to ensure safe and accurate running.

Test item	Content	Criterion
Over charge	Over-charge protection for each cell	3.80±0.03V
	Over-charge release for each cell	3.60±0.05V
	Over-charge release method	Under the release voltage
Over discharge	Over-discharge protection for each cell	2.00±0.05V
	Over-discharge release for each cell	2.30±0.05V
	Over-discharge release method	Charging
Over current	Discharge over current protection	55~65A
	Protection delay time	100~200ms
	Over current release method	Release after cutoff the load.
Over Temperature	Battery over temperature	Protection @65±5℃
		Release @60±5℃

5. Dimensional Drawing

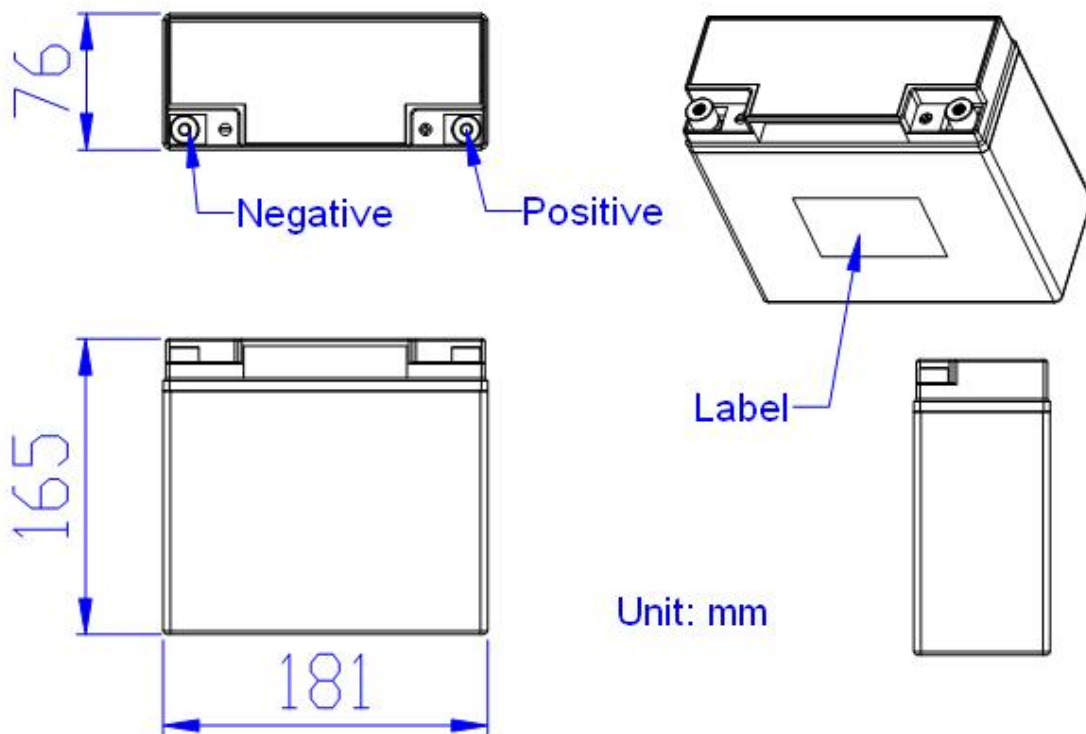

6. Storage & Transportation

- * Based on the character of cell, proper environment for transportation of LiFePO₄ battery pack need to be created to protect the battery.
- * Battery should be stayed in the ware house -20℃~35℃ where it's dry, clean, shade, and well-ventilated.
- * The battery should be stored in 50% SOC during transportation.
- * The battery need to be charged every 6 months if out of use
- * Keep the battery against dropping, turning over and serious stacking during loading.

7. Warning & Tips

Please read and follow the specification and caution remarks on battery surface before use the battery. Improper use may cause heat, fire, rupture, damage or capacity deterioration of the battery. SHENZHEN TOPBAND NEW ENERGY CO.,LTD. Describes is not responsible for any accidents caused by the usage without following our specification.

Warning!

- * The battery must be far away from heat source, high voltage, and avoid to be exposed in sunshine for long time.
- * Never throw the battery into water.
- * Never connect the positive and negative of battery with metal.
- * Never sheep or store battery together with metal.
- * Never reverse two electrodes when use the battery.
- * Never disassemble the battery without manufacturer's permission and guidance.
- * Never knock, throw or trample the battery.

Tips!

- * Keep the battery against high temperature. Otherwise it will cause battery heat, get into fire or lose some function and reduce the life.
- * When battery run out of power, please charge your battery timely (≤ 15 day).
- * Please use the matched or suggested charger for this battery.
- * If battery emit peculiar smell, heating, distortion or appear any abnormality during working or storage, please stop using and take it out from device.
- * If the battery leaks and get into the eyes or skin, do not wipe, instead, rinse it with clean water and see doctor immediately.
- * Please far away from children or pets.
- * Do not put disuse battery into a fire or water.
- * If user needs to parallel several battery packs, please charge them to full capacity with same type of matched charger, and set it aside for 8 hours, professionals only. This battery pack supports application no more than 20 group parallel. If user needs to apply this product to more groups parallel, please reconfirm details with us.
- * It is strictly prohibited any series between the battery packs. Any requirements on serials connection, please contact TOPBAND for details.